



Thank you for purchasing our product. Before installing/operating the product, read the instructions carefully and retain them for future reference.

⚠ Attention!

- For installation, follow the steps described. Any damage caused by wrong installation shall be imputed to the users.
- Maintenance and repairs should be executed by our professionals only.

NOTE

⚠ Some procedures must be followed to avoid damages to the product.

⚠ **WARNING!** Certain procedure must be followed to avoid damages to yourself, to the vehicle or to others.

1 Accessories

<p>1 Extension wire X1</p> 	<p>2 Meter bracket X1</p> 	<p>3 M5 washer X3</p> 	<p>4 M5X12Lmm Screw X3</p> 
---	--	---	---

2-1 Bracket Installation instructions

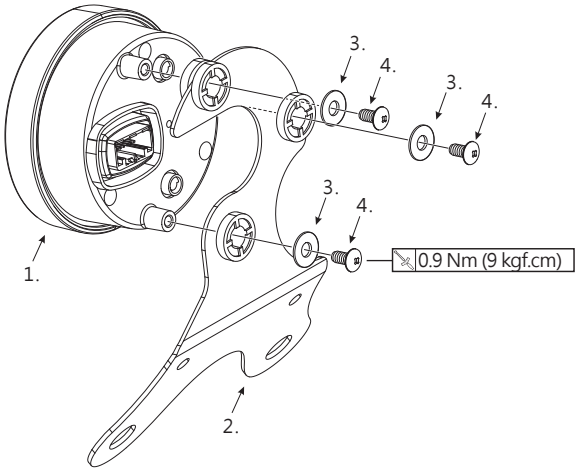

Follow the steps below during installation.

1. LCD Meter
2. Meter bracket (Accessory 2)
3. M5 washer X3 (Accessory 3)
4. M4 screw X3 (Accessory 4) 0.9 Nm (9 kgf.cm)

2-1 Vehicle installation instruction

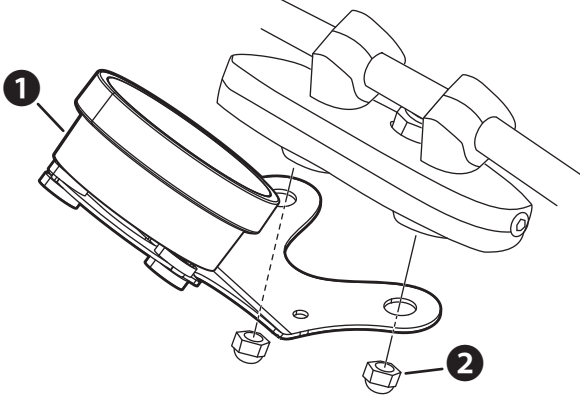

Install in the following order

- 1** LCD Meter (With Bracket)
- 2** Original nut

⚠ Refer to image 2-1 for fixing the bracket to the frame. Consult the Yamaha owners manual for proper torque reference of original nut (item 2).

NOTE Follow the order shown in the figure for installation.

2-4 Wiring Installation Instructions

